

# An Internet Based Wireless Home Automation System for Multifunctional Devices

Ali Ziya Alkar *Member*, IEEE and Umit Buhur,

**Abstract** — *The aim of home automation is to control home devices from a central control point. In this paper, we present the design and implementation of a low cost but yet flexible and secure internet based home automation system. The communication between the devices is wireless. The protocol between the units in the design is enhanced to be suitable for most of the appliances. The system is designed to be low cost and flexible with the increasing variety of devices to be controlled.*<sup>1</sup>

**Index Terms** — Automation, Internet, Microcontroller, RF Communication.

## I. INTRODUCTION

Automation is today's fact, where more things are being completed every day automatically, usually the basic tasks of turning on or off certain devices and beyond, either remotely or in close proximity. The control of the devices when completely taken over by the machines, the process of monitoring and reporting becomes more important. We are more and more relinquishing the power for simple but routine tasks while we need to maintain as much control as we can over the automated processes. Automation lowers the human judgment to the lowest degree possible but does not completely eliminate it. Depending on the location of its usage, automation differs in its name as industrial automation, home automation etc.

With the development of low cost electronic components home automation migrated from being an industrial application to home automation. The home automation, our point of concern deals with the control of home appliances from a central location. Market researches claim that most of the homes will be equipped with home automation systems in the very near future.

There are some published home automation examples such as [1] where the system was based on a dedicated network. [2] proposed another approach where the research was only based on a model and without any implementations. The paper also lacks hardware implementations and based on home appliances with built in controllers and ready for internet access which may be too expensive and complicated to build.

The connection between the server and devices can be realized using wireless or non-wireless approaches. X10 becomes a fine choice for non-wireless communication where for the wireless world IR (infrared), RF (radio frequency) or Bluetooth have been extensively used. In terms of wireless communications between devices [3] proposed an automation system based on Bluetooth without the internet controllability. Another approach proposed is the [4] with no implementations.

The studies in [5][6][7] has some examples of web based automation. However, they are not too feasible to be implemented as a low cost solution [8]. Recently [9] introduced a low cost Java-Based Home Automation System, without highlighting the low level details of the type of peripherals that can be attached.

In this paper we present a low cost secure web based, flexible, wireless solution where the home appliances of most types can be connected to a central node through a server. This paper suggests a framework of the communication protocol between the devices to be used in home automation. To be used in this framework we proposed a novel communication protocol to control devices with more than just the switching functionality. The designed system will be open to expansion and will enable control of different types of devices. The system is designed to be low cost however at the same time more flexible alternative with respect to similar systems.

The next section will briefly introduce the units in the automation system, Section 3, discusses the communication format that is proposed, Section 4 is the conclusion.

## II. THE HOME AUTOMATION SYTEM

To model the system Moog's (Object Management Group) standard visual modeling language UML (Unified Modeling Language) has been used [10]. This gave us a bird's eye view on the design stage as well as during the modeling of the communication between components in the system.

The system and the connections between the nodes in the system are modeled in UML (Fig. 1.). The system is modeled with three different units. The first unit is the PC side which is formed of a user interface component, the database and the web server components. An internet page has been setup running on a Web server. The user interface and the internet front end are connected to a backend data base server.

<sup>1</sup>

Ali Ziya Alkar is with the Hacettepe University, Ankara, 06800, Turkey (e-mail: alkar@hacettepe.edu.tr).

Umit Buhur was with Hacettepe University, Ankara, Turkey. He is now with the 4S Computers, Öveçler, Ankara, Turkey (e-mail: umitbuhur@yahoo.com).

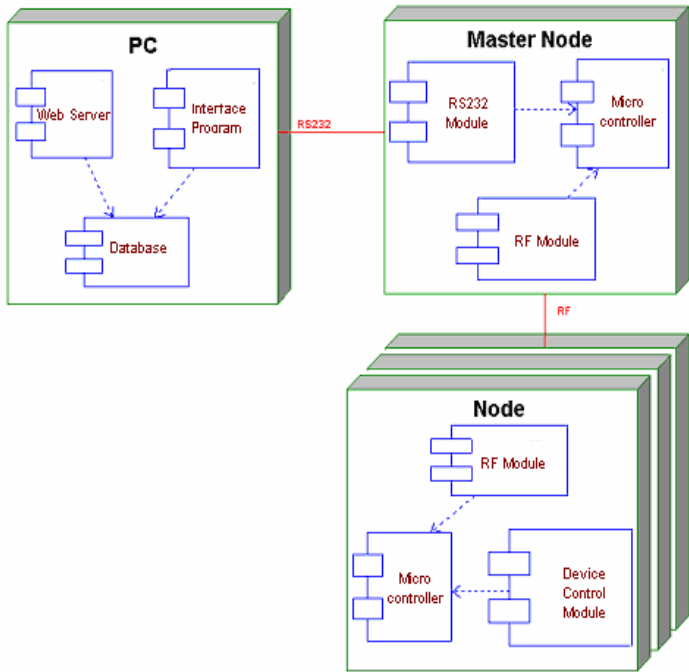

Fig. 1. Complete System Deployment Diagram

The master node has a RS232 communication interface used for computer and serial communications and an RF communication unit for wireless data transfer between other nodes in the system and a microcontroller unit to manage all the data transfers. Also there exists a low cost microcontroller to maintain the communication between nodes.

The final node in the list is the hardware connected to the actual devices to be integrated to the system. This node is also formed of an RF communication unit to connect to the manager node plus a component to establish communication between devices connected on the node and a microcontroller to organize the data flow to and from the master.

A. The PC Unit

The control of devices is established and their condition is monitored through the internet. As the manager unit a computer has been used. The programs that are running on the computer are listed as follows:

- Web server and Internet Web Page
- Database and its platform
- User Interface Program

Through the internet we can access the database directly. The status changes that are reflected to the database are transferred to the device through first the master and then to the slave nodes, which will be described in the next section. The connection to the web page is secured through the server certificate and the SSL algorithm. In addition a login/password based access is setup to prevent unauthorized accesses. With the internet page, authorized users can login to

their home environment, monitor and change the status of the devices of their choice.

Database is formed of three tables internally: Divisions of the house, devices and tables storing the status of tables as shown in Fig. 2.

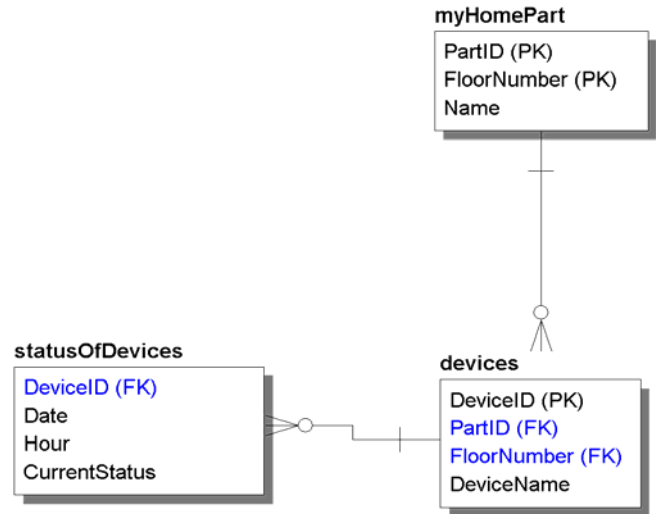

Fig. 2. Database organization chart

Microsoft SQL Server is used for the database and DB Artisan for database management. The tables in the database are shown in Fig. 3. Under a single device number there may be different states stored indicating different status of the devices at different time intervals. Thus with this system history for each device can be stored and retrieved for later processing.

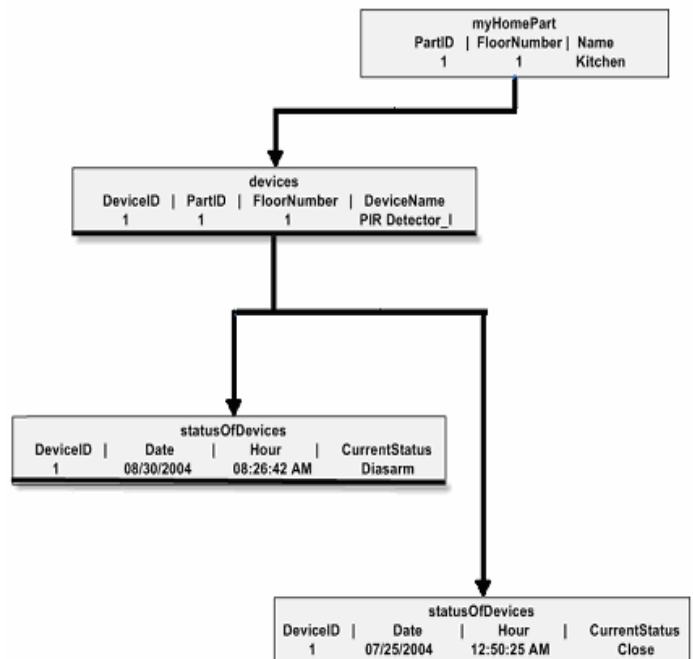

Fig. 3. Database data storage hierarchy

A user interface is built to bridge the database with the hardware attached. Along being a user interface this program with certain intervals synchronizes the status of the devices to match their status with the database value. If there is any change in status of a device in the database, this change is synchronized with the device. Similarly the statuses of the devices are updated on the database as the conditions on devices change.

*B. The Nodes*

The hardware part is formed of two main parts; the master node and the slave nodes. The nodes direct the devices that are attached to with the information received from the master node and inform the master with the status information of these devices.

The master node's duty is to transmit the information that is directed by the computer to the nodes and to transmit the reply back to the computer. The master node establishes the communication to the computer via an RS232 interface. The communication between the master and the slave nodes is established through RF. The modulation of the RF communication is performed using an FM modulator working at 433MHz frequency and 9600Kbps speed. The RF was a low cost communication decision and the reliability has proved to be sufficient for a reliable communication. The master node is connected to the subnodes and to the computer through a switching circuitry. The information that is sent and received is simultaneously displayed on the LED indicator in encoded form for test purpose as shown in Fig. 4(a) and (b).

The master node is designed to work as a standalone unit where the computer connectivity is not absolutely necessary to maintain the regular operation of the devices except making modifications or monitoring on them.

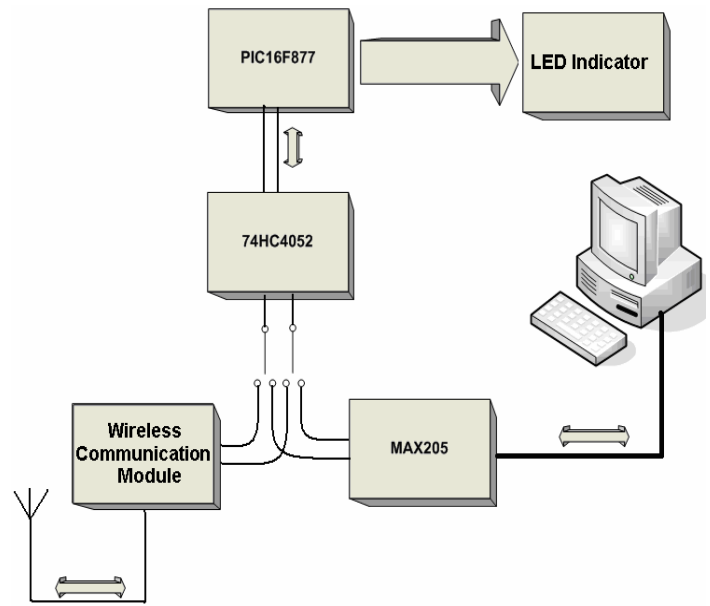

**Fig. 4(b). Master Node Implementation and its block diagram**

Slave Nodes, as shown in Fig. 5(a) and (b), are connected directly to the devices to be controlled. By querying the slave nodes the status of the devices can be acquired.

The initial task of the nodes is to check first if the information sent by the manager node is directed to their node ID. After this, the nodes check if the data sent belongs to one of the addresses of a device that is attached. If the device ID matches one of the devices attached then the necessary changes are performed by the node and the status of the device is updated and sent back to the manager node.

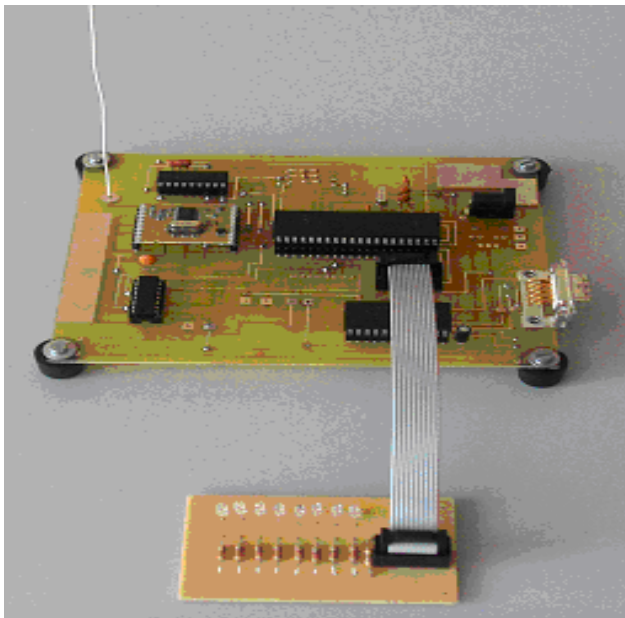

**Fig. 4(a): Master Node Implementation and its block diagram**

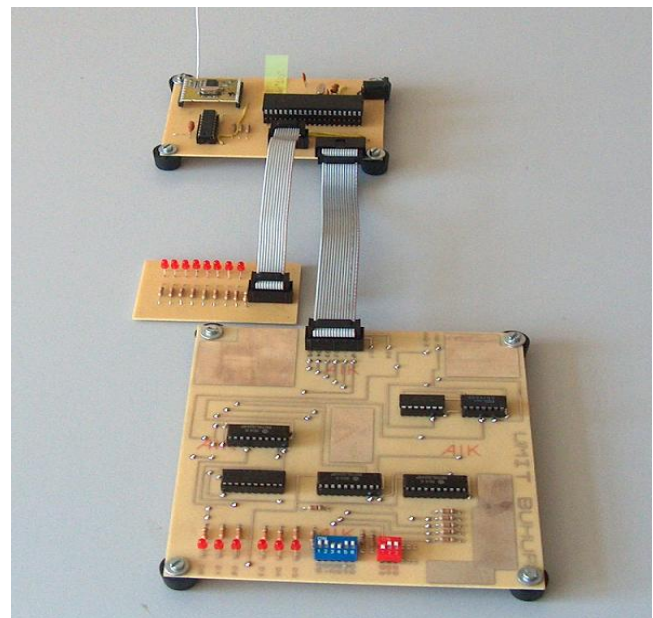

**Fig. 5(a): Manager Node Implementation with test circuitry and its Block Diagram.**

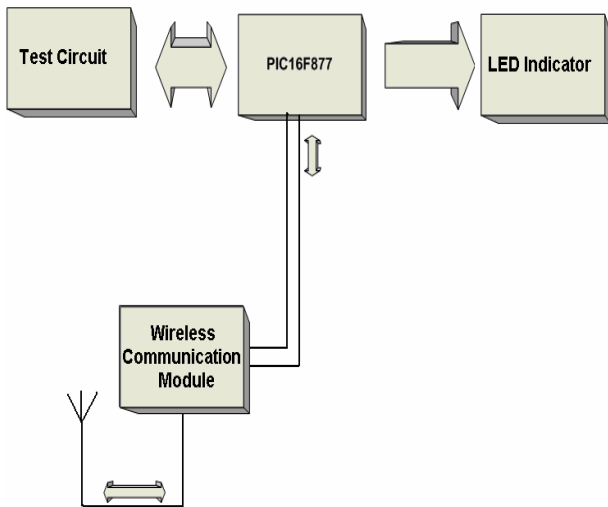

Fig. 5(b). Manager Node Implementation with test circuitry and its Block Diagram.

### III. THE COMMUNICATION

The devices to be used in the automation should be grouped initially with respect to the classification of the common commands that the devices can handle. For example the events like on/off action, motion detection, fire alarm is classified into a single group since these only require a certain similar action commands to perform. A sample application for on/off operation of a device is in Fig. 6. These devices can use a similar interface circuitry if they are included in this group.

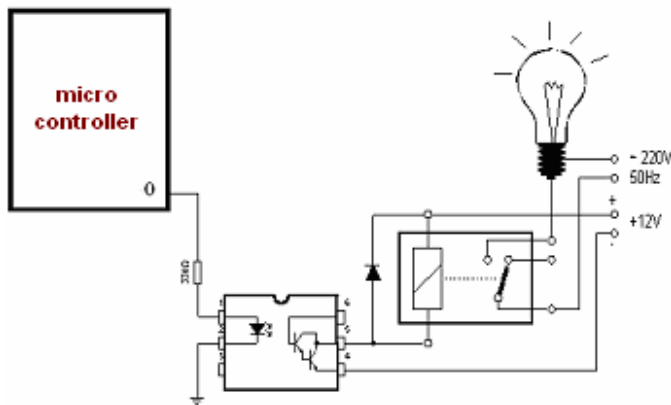

Fig. 6: Simple Light control

For a device in this group where a limited set of instructions are adequate the instruction format is given in Fig. 7. In this format, 7 out of 8 commands are currently used, which can fit in the command word using only 3 bits of the byte. These commands can be an On/Off command in the simplest sense or an alarm or some other predefined settings to a certain level of light intensity (a macro definition) for example.

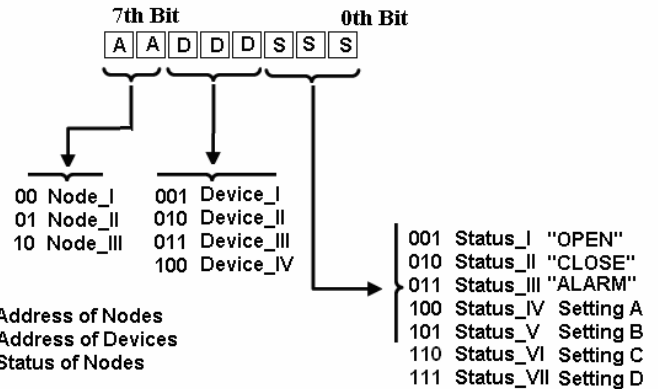

Fig. 7: Format for simple set of functionality

The other devices such as the ones that require an analog signal control can also be classified in a different group such as a Volume Switch, a Dimmer or a Heater. In this way the devices using a complicated set of instructions can also be controlled. This format is more suitable as an input to a D/A converter.

In this group of devices, it is not possible to control these devices using only 7 different instructions as in the previous simple configuration. Devices in this group need more information to define their status thus their instructions are more complicated. As seen in Fig. 8, as the properties of these devices increase, the bit size used for an instruction is increased. These groups of devices are communicated through 9 bit instructions allowing adjustment up to 512 different settings. In addition, in this more complex format the device number is increased to 32 instead of 8 as in the previous case. These two groups of devices are allowed to coexist in the same system thus reducing the redundant byte transfer for simpler devices.

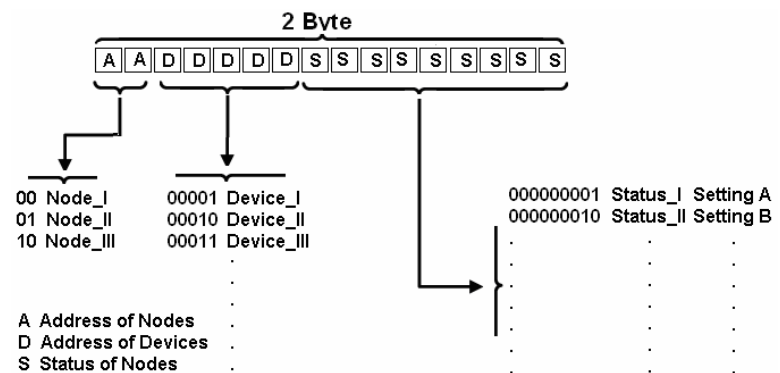

Fig. 8: Format for complicated set of functionality

During the transmission between the master node and the other nodes, CRC error checking mechanism and the Manchester coding techniques are used [11] to ensure the integrity of the data. The nodes and the manager node use a query reply communication protocol. As the nodes are queried, they return their status to the manager node. In the

verification of a reply being received by the slave node, the slave sends back the exact command to the device that is sending the command. For instance, if a node receives a command for a change in the status of one of its devices, it changes the status of the device first, and sends back the same command to the Master Node. Similarly when the nodes are asked about the status of its device the reply is again the command received with the status information to complete the transmission.

Framing is used (Fig. 9) to decrease error possibility and increase efficiency. The framing consists of the following:

- Preamble
- Start Byte
- Address
- Data Length
- Data
- CRC
- End of Frame data

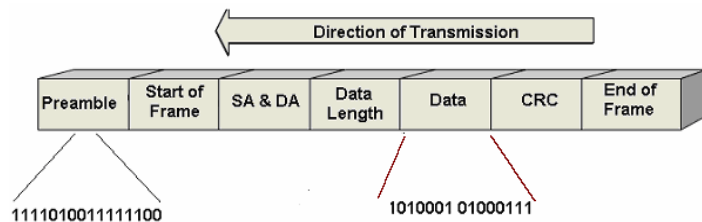

Fig. 9: Framed data

In the initial phase of the design of system a single byte version for the data is designed. This single byte is used both in the addressing of the nodes and the devices as well as defining the status information of the devices. Later when the single byte data is found to be insufficient in representation of more functionality the data length is increased to 2 bytes. The implementation is carried out to accommodate several different data lengths in the same system. The data length can be further increased for different kinds of applications.

The devices are attached to the node in Plug and Play fashion. A confirming device can be simply added to the network by simply plugging it to the physically closest possible node. Upon connection the device introduces itself to the network as a complex device or a simple device (informing the byte length) and registers itself with the main node through an ID on its EPROM. Then further communication with the device is carried out with that ID.

#### IV. CONCLUSION

In this paper we introduced a low cost, flexible, wireless solution to the home automation. The novel approach in this paper discusses the migration of the initial control mechanism of devices with simple functionality to more complex devices which has not been discussed at this level before.

The system is secured for access from outside through an SSL algorithm protected server. The users are expected to acquire login and password to access to the site. This adds protection from unauthorized accesses.

As a feature work we are currently working to establish a more secure means to isolate other RF devices being added to the home network without authorization. This is currently done through a simple handshaking protocol by manually authorizing a connection through the user interface.

During tests, the full functionality of the network was tested and the wireless communication was found to be limited to <100 meters in a concrete building although a 200 meter range was reported to be applicable in open range.

The manipulation or monitoring in the system will be disrupted temporarily during a power outage on the PC side however the system is capable of maintaining the current status during a power outage with backup batteries.

In the system at all stages we have used low cost easy to find components<sup>2</sup>. All these choices of devices were the least possible alternatives making the whole system a low cost solution to the home automation. An embedded version of this system with a network capable PC processor embedded in a single package with the master node is also in progress.

#### REFERENCES

- [1] Neng-Shiang Liang; Li-Chen Fu; Chao-Lin Wu; "An integrated, flexible, and Internet-based control architecture for home automation System in the Internet era," Proceedings ICRA 2002. IEEE International Conference on Robotics and Automation, Vol. 2, pp. 1101 –1106, 2002
- [2] J. C. Nunes and J. C. M. Delgado, "An Internet application for home automation," Electrotechnical Conference, 2000. MELECON 10th Mediterranean, Vol. 1, pp. 298 -301, 2000.
- [3] N. Sriskanthan and Tan Karande, "Bluetooth Based Home Automation Systems," Journal of Microprocessors and Microsystems, Vol. 26, pp. 281-289, 2002.
- [4] R. Shepherd "Bluetooth Wireless Technology in the Home," Electronics & Communication Engineering Journal, Vol. 13 Issue.5, pp. 195 -203, October 2001.
- [5] K. Tan, T. Lee and C. Yee Soh, "Internet-Based Monitoring of Distributed Control Systems-An Undergraduate Experiment," IEEE Transactions on Education, Vol. 45, No. 2, May 2002.
- [6] Chi Chung Ko, Ben M. Chen, Shaoyan Hu, Vikram Ramakrishnan, Chang Dong Cheng, Yuan Zhuang, and Jianping Chen, "A Web-Based Virtual Laboratory on a Frequency Modulation Experiment," IEEE Transactions on Systems, Man, and Cybernetics-Part C: Application and Reviews, Vol. 31, No. 3, pp. 295-303, August 2001.
- [7] N. Swamy, O. Kuljaca and F. Lewis, "Internet-Based Educational Control Systems Lab Using Net-meeting," IEEE Transaction on Education, Vol. 45, No. 2, pp. 145-151, May 2002.
- [8] P. Lin and H. Broberg, "HVAC Applications," IEEE Industry Applications Magazine, pp. 49-54, January 2002.
- [9] A. R. Al-Ali and M. AL-Rousan, "Java-Based Home Automation System", IEEE Transactions on Consumer Electronics, Vol. 50, No. 2, MAY 2004
- [10] Bernd Oestereich, Developing Software with UML, Addison Wesley, 1999 (49-95, 173-180, 262, 273).
- [11] Simon Haykin, Digital Communications, Wiley, 1988

<sup>2</sup> PIC16F877 as a microcontroller, RF communication RXQ1 -RF600T, and the MAX205 interface, also (a PC with Pentium III processor was adequate for the system.



**Ali Ziya Alkar received his B.S. degree in 1988 at Electrical & Electronics Engineering Department, Hacettepe University, Ankara, Turkey. He completed his M.S. study in 1991 at the Electrical & Computer Engineering Department of the University of Colorado at Boulder, Colorado, U.S.A. In 1995 he received his Ph.D. from the same university. His main interests are validation of VLSI designs using hardware description languages, high level synthesis, microprocessor architecture and design and application of security algorithms to VLSI and embedded systems. Supervised and completed several government funded research projects. He is an Assistant Professor at the Dept. of Electrical and Electronics Engineering, Hacettepe University. He is a member of IEEE.**



**Umit Buhur received his B.S. degree in Electrical & Electronics Engineering Department, Hacettepe University, Ankara, Turkey in 2002. Later, he completed his M.S. study also at the Electrical & Electronics Engineering Department, Hacettepe University in 2004. He has several work experiences in the industry. He has research and experience in programming and embedded systems and automation.**